

The information in this document is subject to change without notice and should not be construed as a commitment by ABB. ABB assumes no responsibility for any errors that may appear in this document.

Except as may be expressly stated anywhere in this document, nothing herein shall be construed as any kind of guarantee or warranty by ABB for losses, damages to persons or property, fitness for a specific purpose or the like.

In no event shall ABB be liable for incidental or consequential damages arising from use of this document.

This document and parts thereof must not be reproduced or copied without ABB's written permission, and contents thereof must not be imparted to a third party nor be used for any unauthorized purpose. Contravention will be prosecuted.

Additional copies of this document may be obtained from ABB at its then current charge.

© Copyright 2015 ABB ALL right reserved.

ABB AB

SE-721 68 Västerås
Sweden

We reserve all rights in this document and in the information contained therein. Reproduction, use or disclosure to third parties without express authority is strictly forbidden. © Copyright 2003 ABB

Latest revision: ECO 77348, WI 109538 Page 10: Wire no 3 added.		 Lab/Office: DMRO SE PRIM	IRB 8700 COPYRIGHT page	Status: 2016-01-14 APPROVED Document no. 3HAC051028-002	Plant: = IRB8700 Location: + Manipulator Sublocation: + Rev. Ind 01 Page 1 Next 2 Total 13
Prepared by, date: Erik Mesaros	Approved by, date: Jan-Erik Nähls				

Table of contents

Page	Page description	Comment
1	COPYRIGHT page	
2	Table of contents: (1 - 80)	
3	Valid For	
4	Location of connection points	
5	Legend	
10	Brake Release Unit	
20	Serial Measuring Board	Incl. 7th axis connection (optional)
30	Axis 1	
40	Axis 2	
50	Axis 3	Incl. external lamp (optional)
60	Axis 4	
70	Axis 5	
80	Axis 6	

We reserve all rights in this document and in the information contained therein. Reproduction, use or disclosure to third parties without express authority is strictly forbidden. © Copyright 2003 ABB

Latest revision: ECO 77348, WI 109538
Page 10: Wire no 3 added.

Prepared by, date: Erik Mesaros Approved by, date: Jan-Erik Nähls



Lab/Office:
DMRO SE
PRIM

IRB 8700
Table of contents: (1 - 150)

Status: 2016-01-14
APPROVED
Document no.
3HAC051028-002

Plant: = IRB8700
Location: + Manipulator
Sublocation: +

Rev. Ind 01	Page 2 Next 3 Total 13
-----------------------	------------------------------

Valid For:
 This circuit diagram is valid for the following cable harness assemblies:
 3HAC050792-001: Manipulator harness axis 1-6
 (3HAC046642-001: Brake release unit
 3HAC043904-001: SMB unit
 3HAC15619-2: Cable, FB7-SMB 1.7
 3HAC044075-001: Battery unit
 3HAC046287-001: Cable, battery-SMB
 3HAC047052-001 UL signal lamp)

We reserve all rights in this document and in the information contained therein. Reproduction, use or disclosure to third parties without express authority is strictly forbidden. © Copyright 2003 ABB

Latest revision: ECO 77348, WI 109538 Page 10: Wire no 3 added.		 Lab/Office: DMRO SE PRIM	IRB 8700 Valid For	Status: 2016-01-14 APPROVED Document no. 3HAC051028-002	Plant: = IRB8700 Location: + Manipulator Sublocation: +	Rev. Ind 01	Page 3 Next 4 Total 13
Prepared by, date: Erik Mesaros	Approved by, date: Jan-Erik Nähls						

We reserve all rights in this document and in the information contained therein. Reproduction, use or disclosure to third parties without express authority is strictly forbidden. © Copyright 2003 ABB

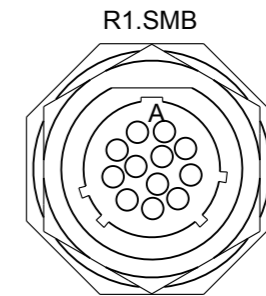
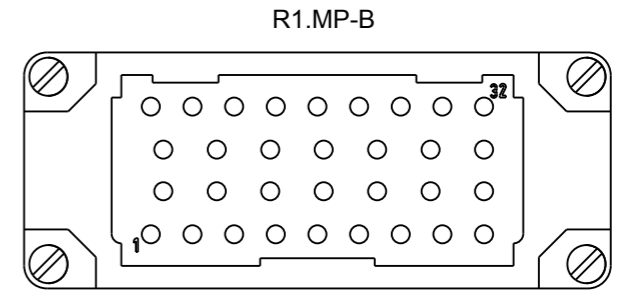
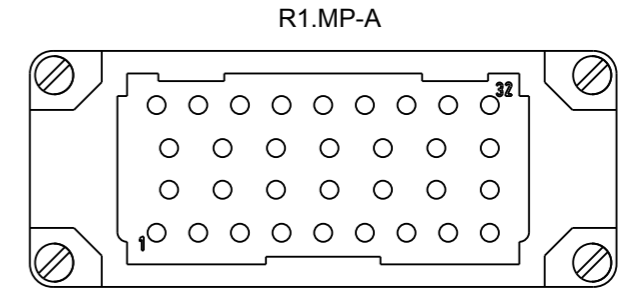
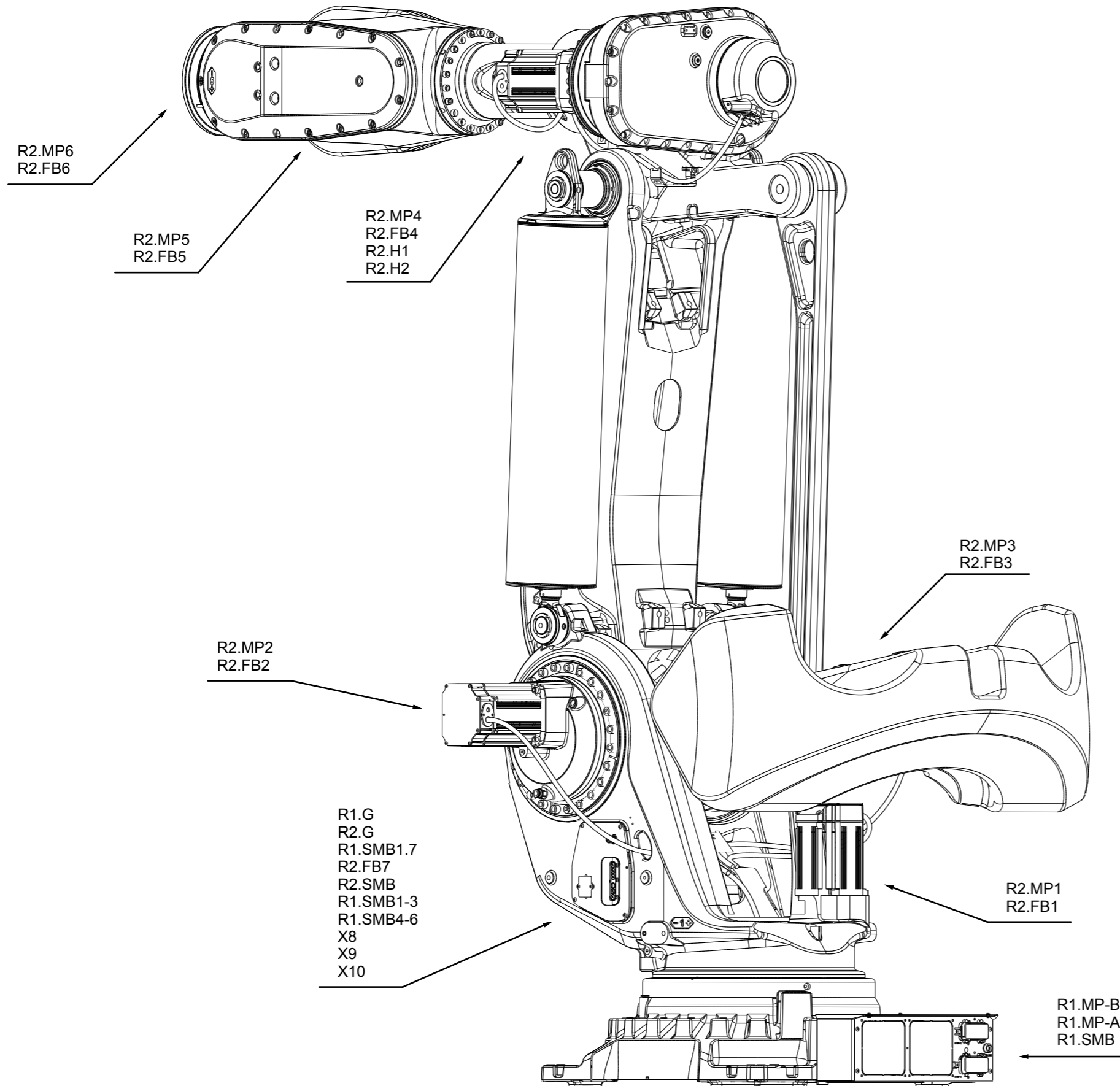

R1.MP-B
R1.MP-A
R1.SMB

Latest revision: ECO 77348, WI 109538 Page 10: Wire no 3 added.		Lab/Office: DMRO SE PRIM	IRB 8700 Location of connection points	Status: 2016-01-14	Plant: = IRB8700
				APPROVED	Location: + Manipulator
Prepared by, date: Erik Mesaros	Approved by, date: Jan-Erik Nähls			Document no. 3HAC051028-002	Rev. Ind 01
				Page 4 Next 5 Total 13	

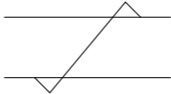
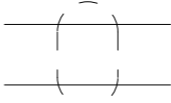
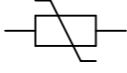
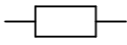
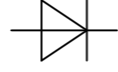
M	Motor		Protective Earth
B	Brake		
PTC	Temp sensor (PTC- resistor)		Twisted wires
R	Resolver		
G	Battery Pack		Screened wires
BU	Brake Release Unit		Varistor
FB	Feedback unit		Resistor
SMB	Serial Measurement Board		
FAN	Fan		Diode
SW	Position switch		
Keypin	Location pin to avoid mismatch		

We reserve all rights in this document and in the information contained therein. Reproduction, use or disclosure to third parties without express authority is strictly forbidden. © Copyright 2003 ABB

We reserve all rights in this document and in the information contained therein. Reproduction, use or disclosure to third parties without express authority is strictly forbidden. © Copyright 2003 ABB

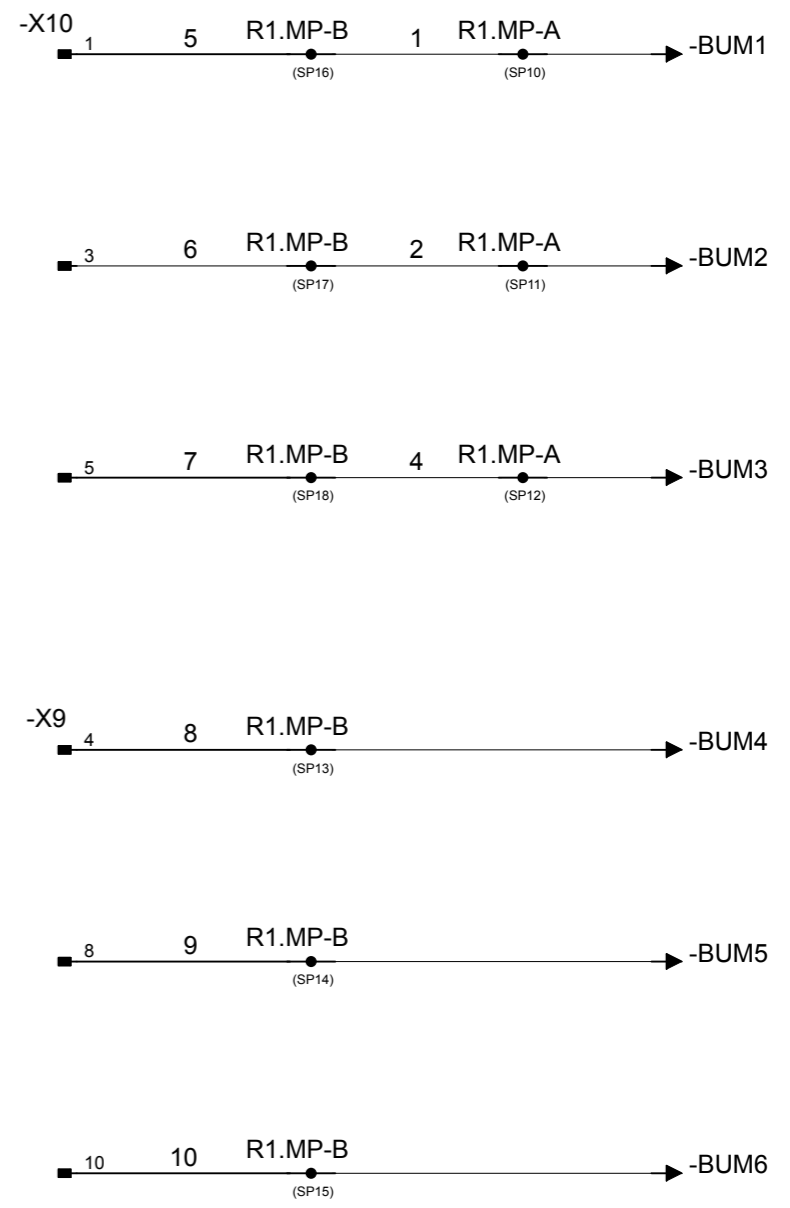
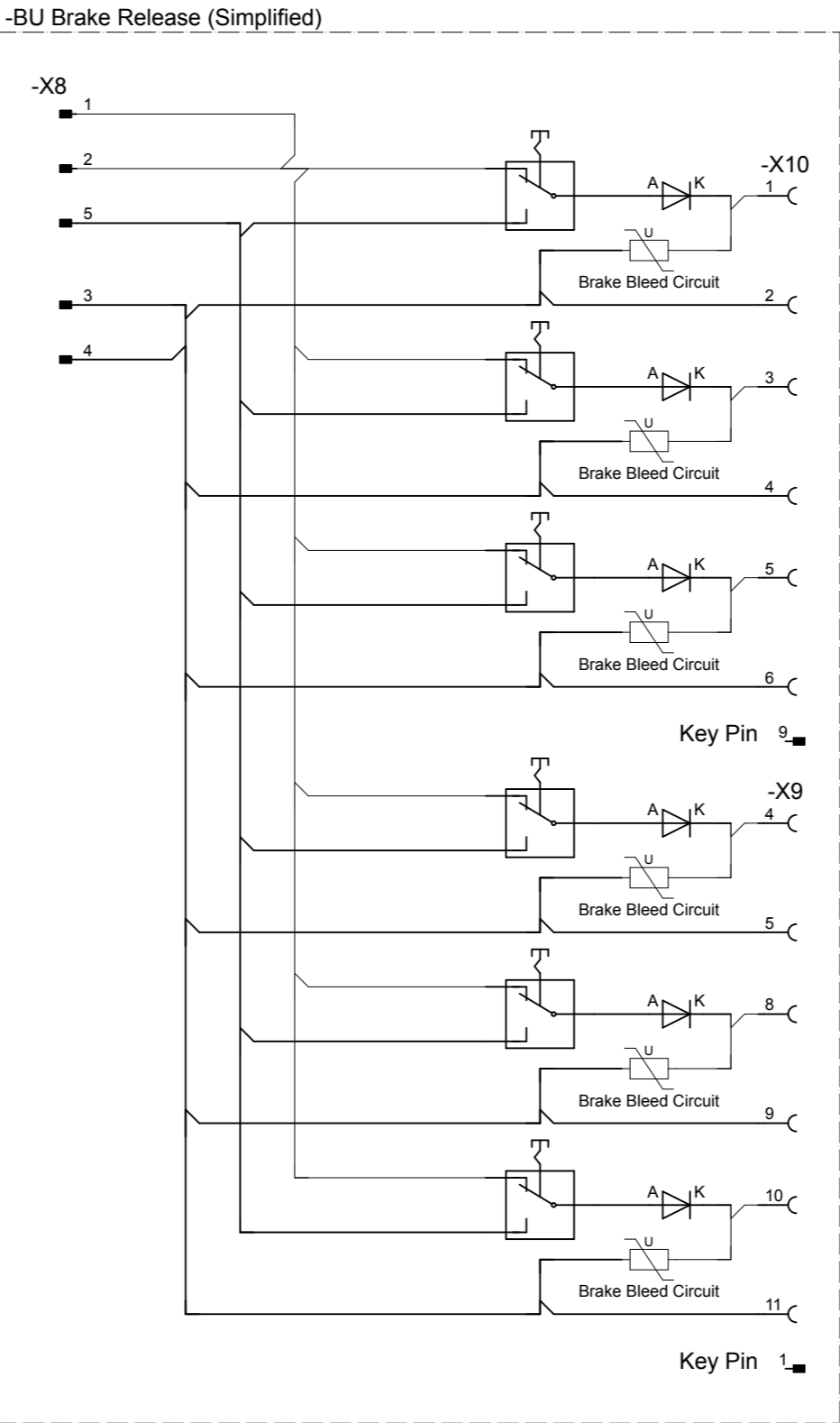
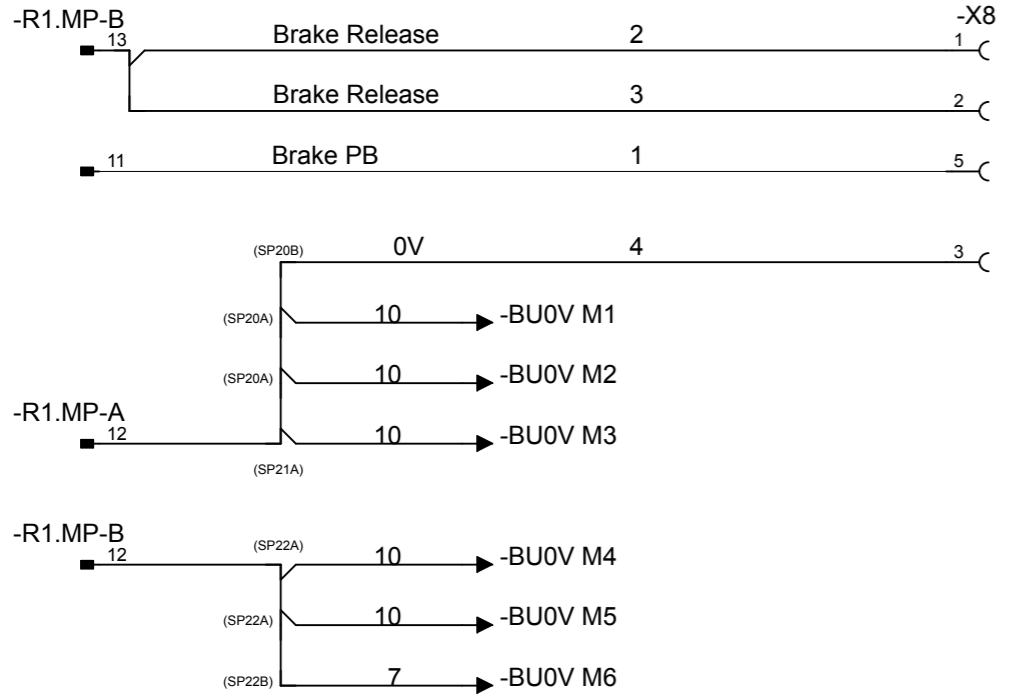

Latest revision: ECO 77348, WI 109538
Page 10: Wire no 3 added.



Lab/Office:
DMRO SE
PRIM

IRB 8700

Brake Release Unit

Status: 2016-01-14

APPROVED

Document no.
3HAC051028-002

Plant: = IRB8700
Location: + BU
Sublocation: +

Rev. Ind
01

Page 10
Next +SMB/2
Total 13

Prepared by, date: Erik Mesaros Approved by, date: Jan-Erik Nähls

We reserve all rights in this document and in the information contained therein. Reproduction, use or disclosure to third parties without express authority is strictly forbidden. © Copyright 2003 ABB

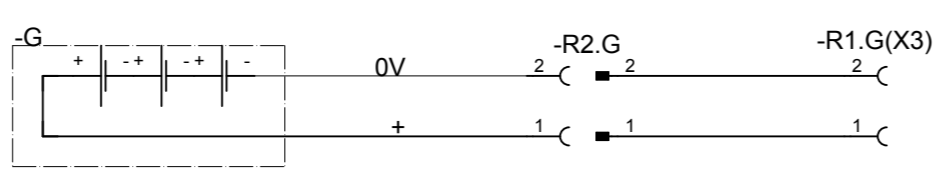
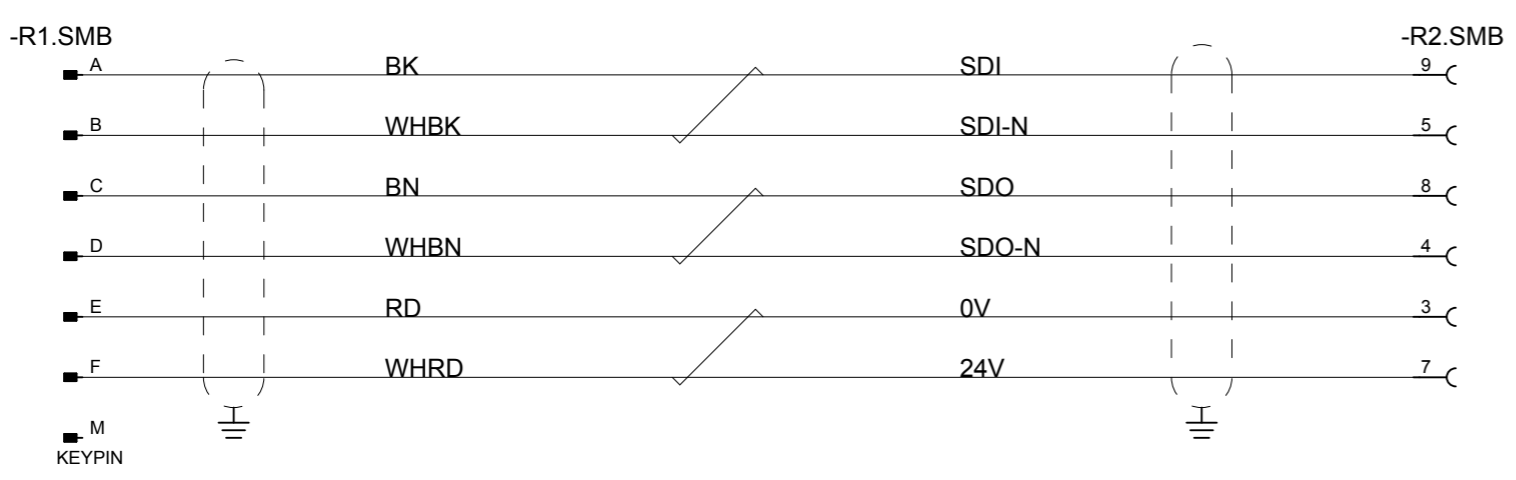
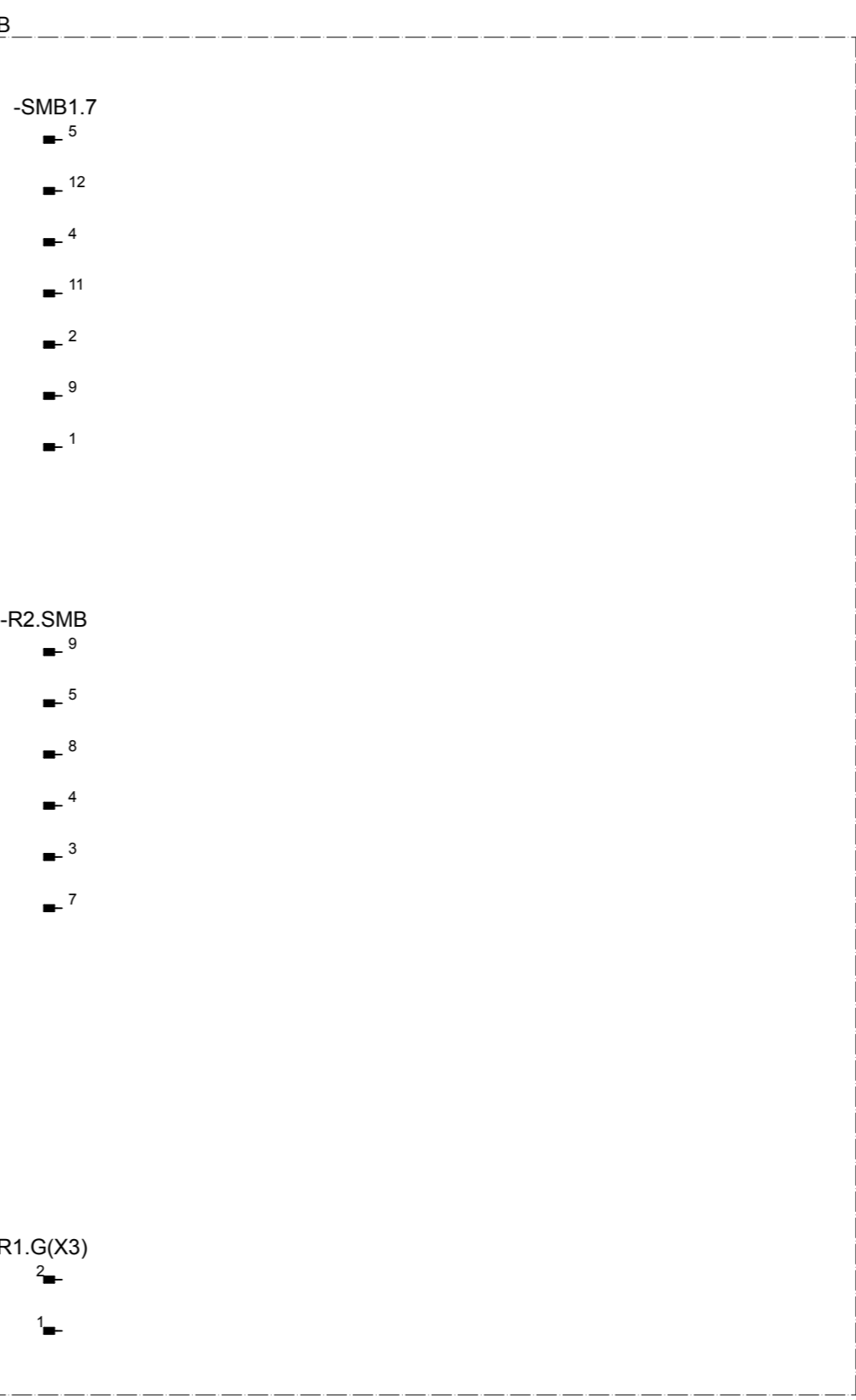
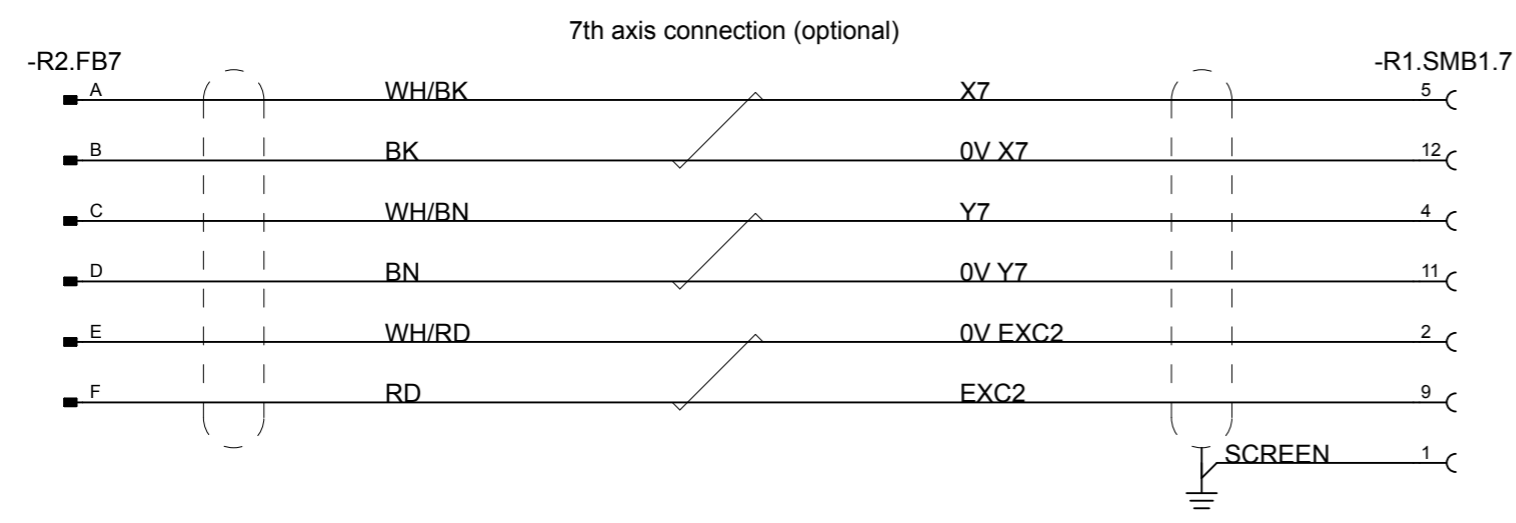

Latest revision: ECO 77348, WI 109538
Page 10: Wire no 3 added.

Prepared by, date: Erik Mesaros
Approved by, date: Jan-Erik Nähls



Lab/Office:
DMRO SE
PRIM

IRB 8700
SMB, incl optional 7th axis connection

Status: 2016-01-14
Plant: = IRB8700
Location: + SMB
Sublocation: +

Document no. 3HAC051028-002
Rev. Ind 01
Page 20
Next +Axis 1/
Total 13

We reserve all rights in this document and in the information contained therein. Reproduction, use or disclosure to third parties without express authority is strictly forbidden. © Copyright 2003 ABB

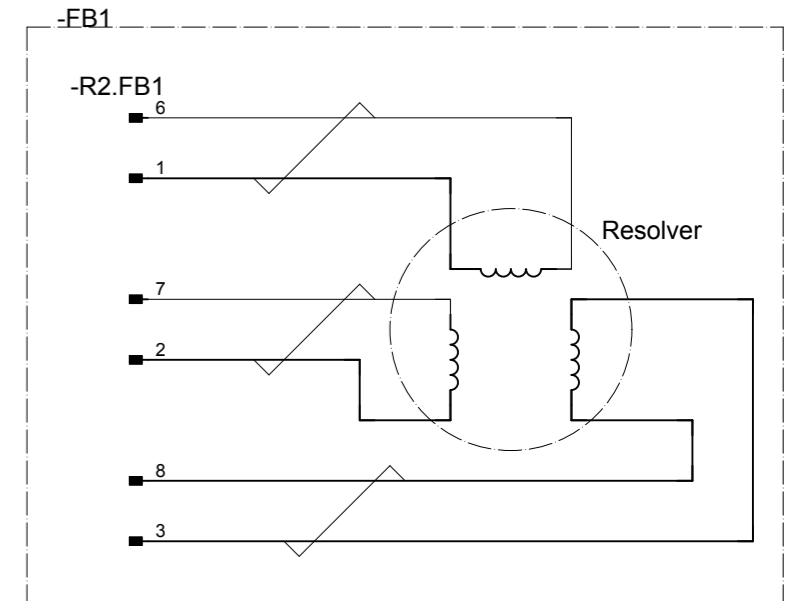
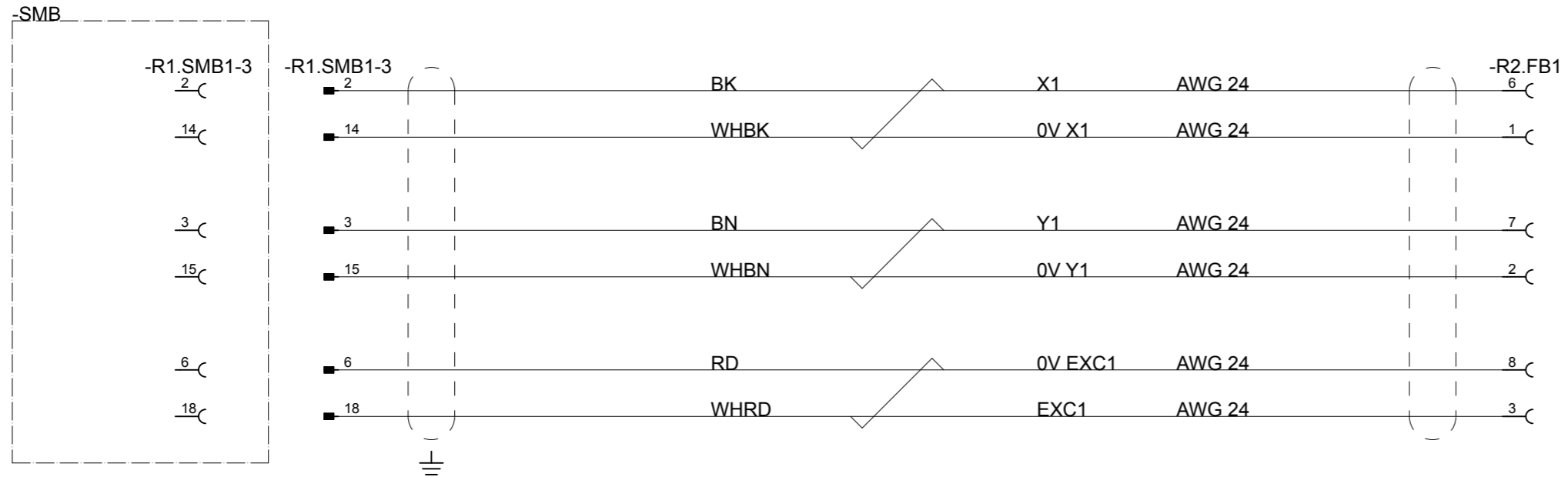
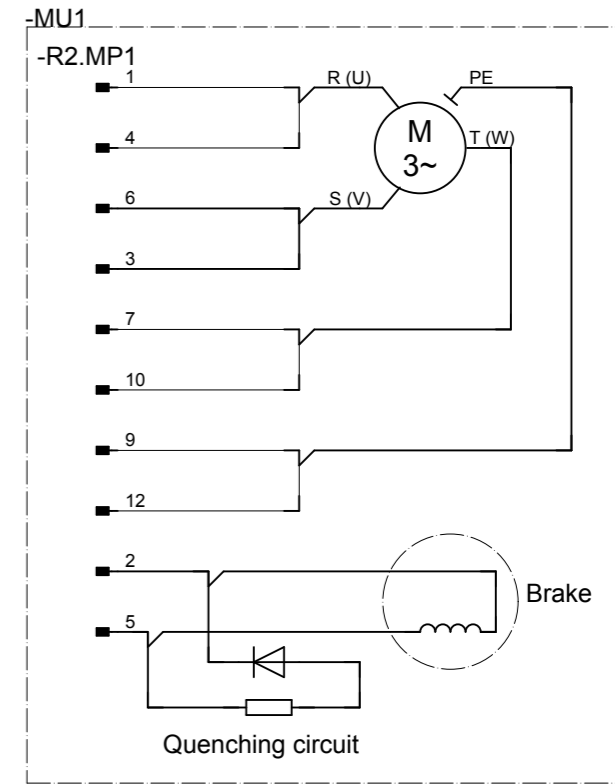
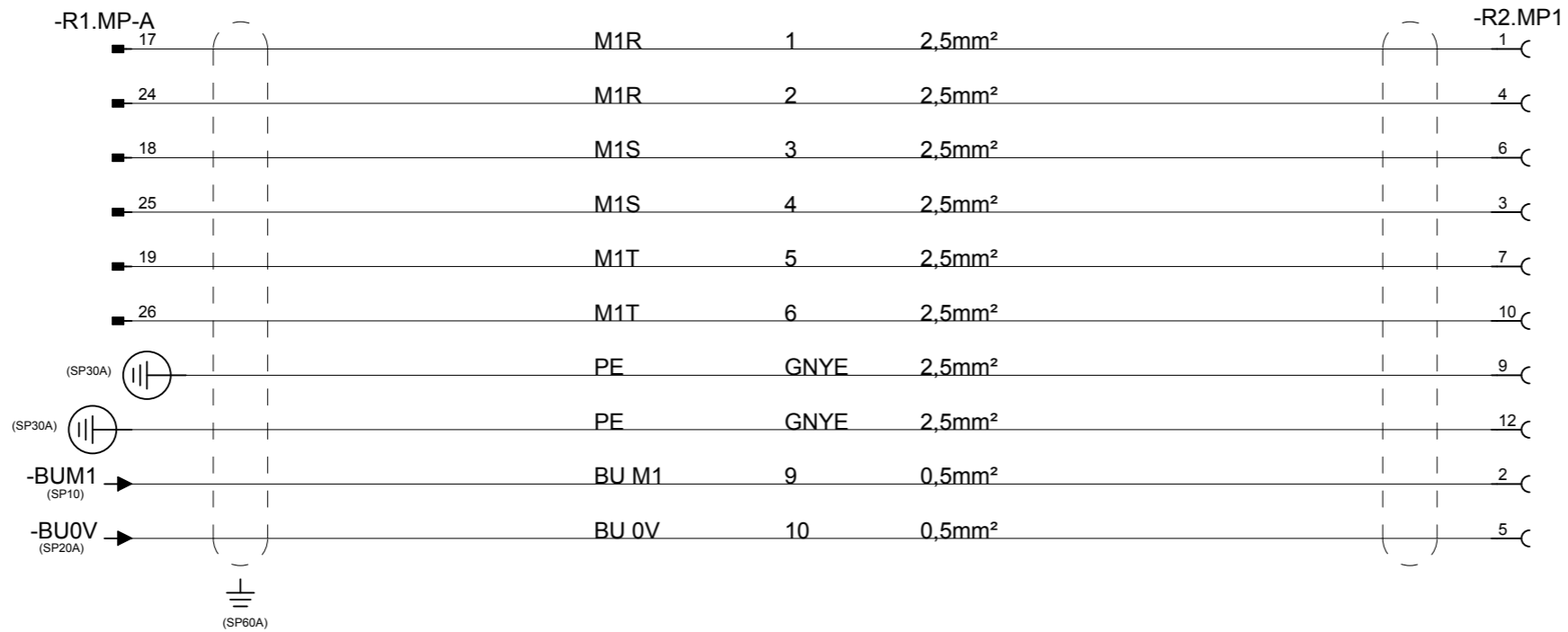

Latest revision: ECO 77348, WI 109538
Page 10: Wire no 3 added.



Lab/Office:
DMRO SE
PRIM

IRB 8700

Axis 1

Status: 2016-01-14

APPROVED

Document no.

3HAC051028-002

Plant: = IRB8700

Location: + Axis 1

Sublocation: +

Rev. Ind

01

Page 30

Next +Axis 2/

Total 13

Prepared by, date: Erik Mesaros Approved by, date: Jan-Erik Nähls

We reserve all rights in this document and in the information contained therein. Reproduction, use or disclosure to third parties without express authority is strictly forbidden. © Copyright 2003 ABB

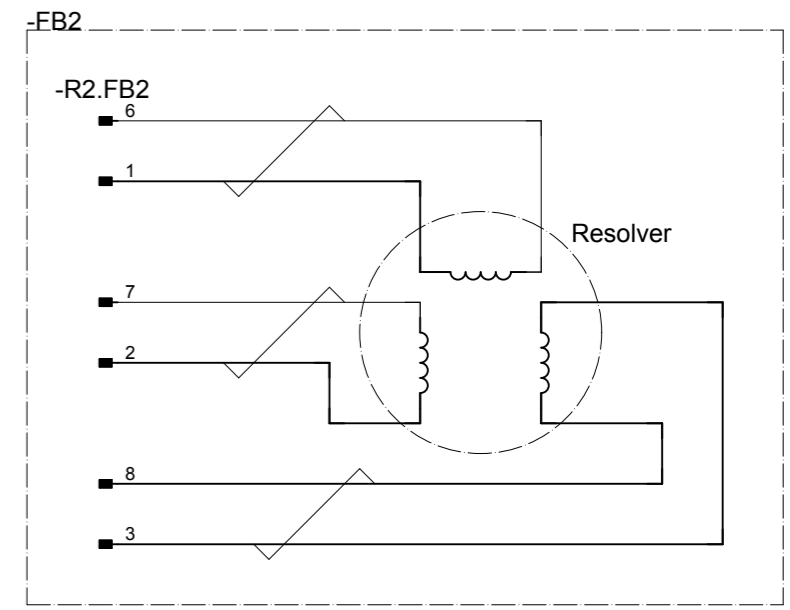
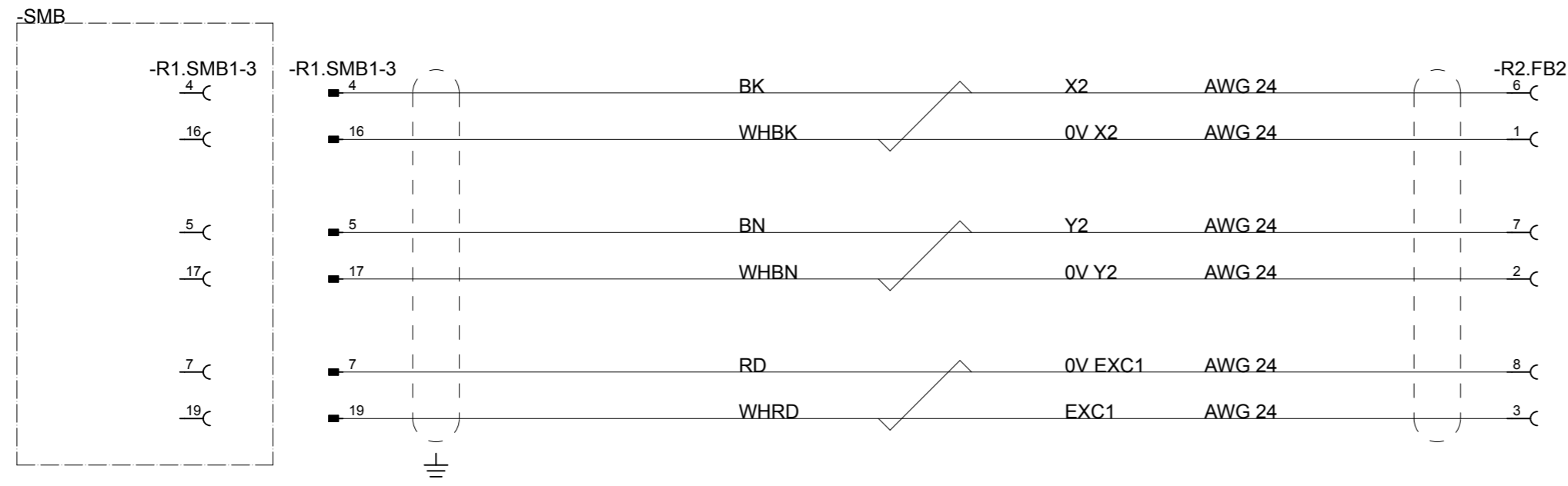
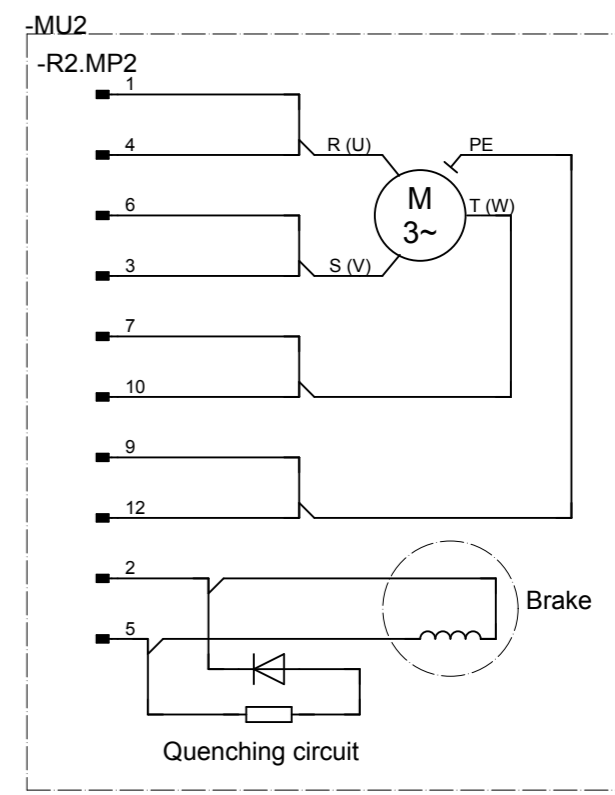
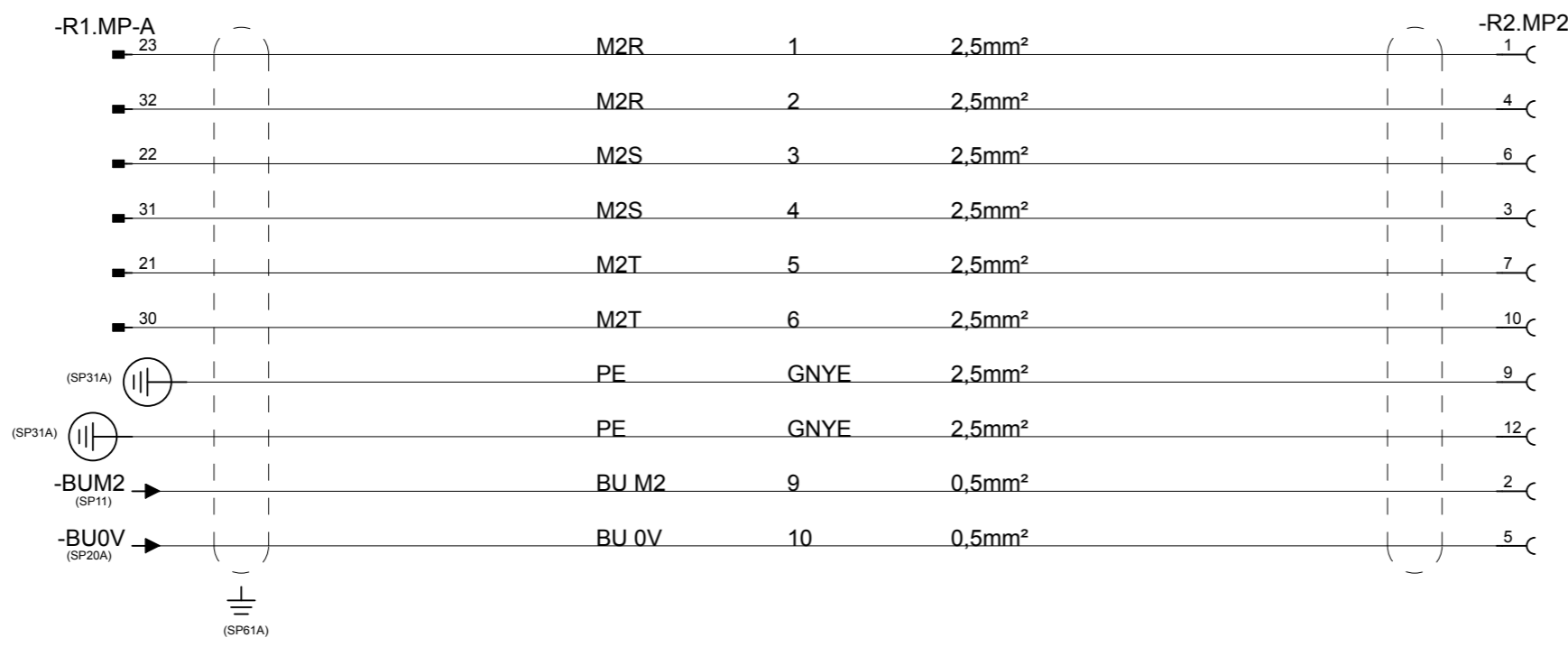

Latest revision: ECO 77348, WI 109538
Page 10: Wire no 3 added.

Prepared by, date: Erik Mesaros
Approved by, date: Jan-Erik Nähls



Lab/Office:
DMRO SE
PRIM

IRB 8700
Axis 2

Status: 2016-01-14
Plant: = IRB8700
Location: + Axis 2
Sublocation: +

APPROVED

Document no. 3HAC051028-002

Rev. Ind 01

Page 40
Next +Axis 3/
Total 13

We reserve all rights in this document and in the information contained therein. Reproduction, use or disclosure to third parties without express authority is strictly forbidden. © Copyright 2003 ABB

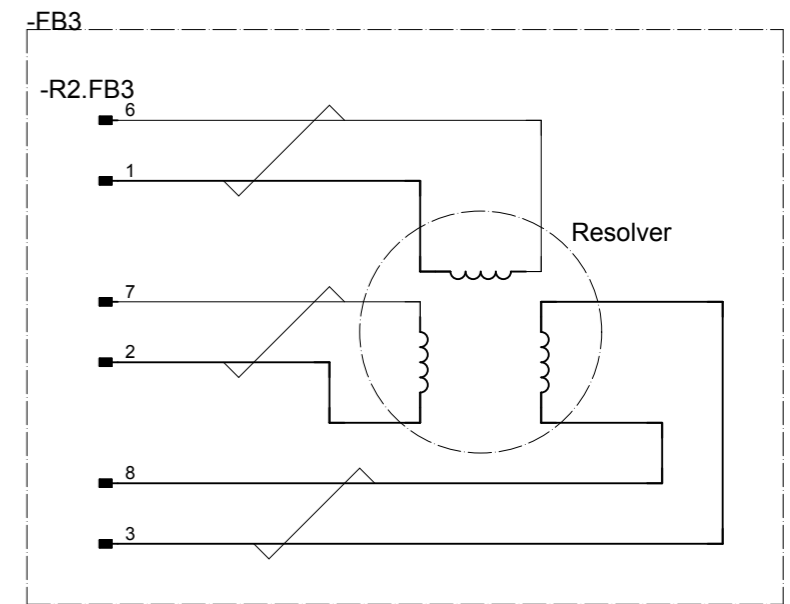
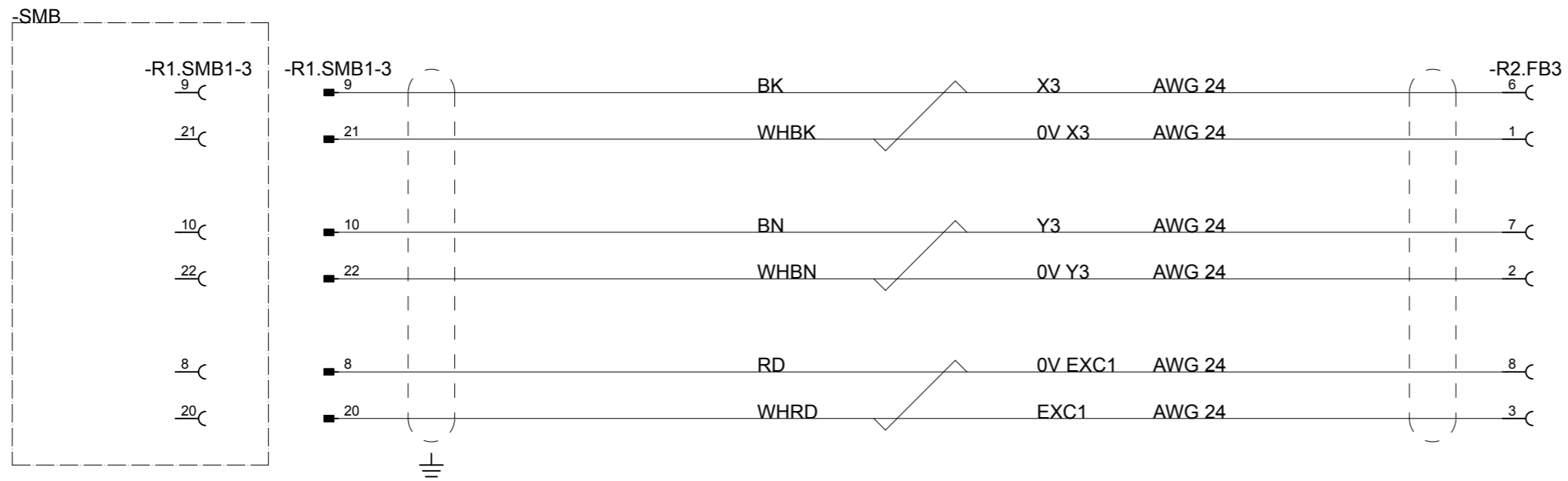
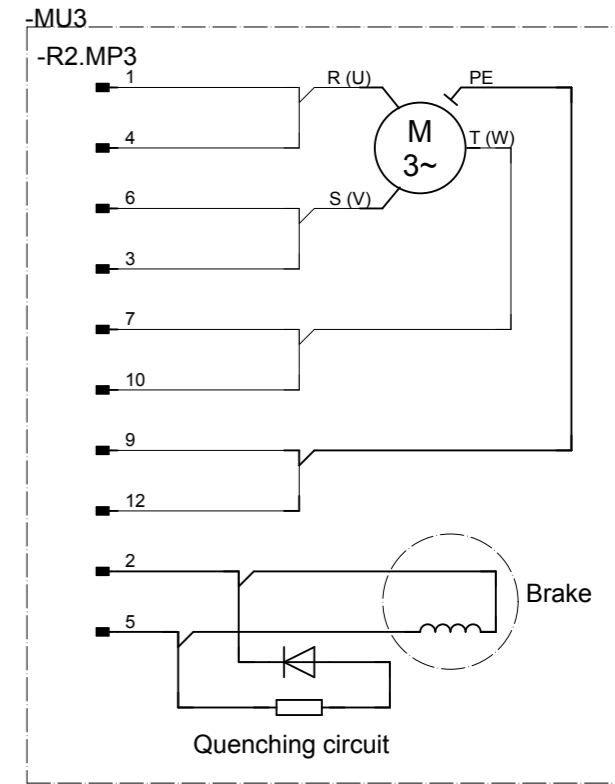
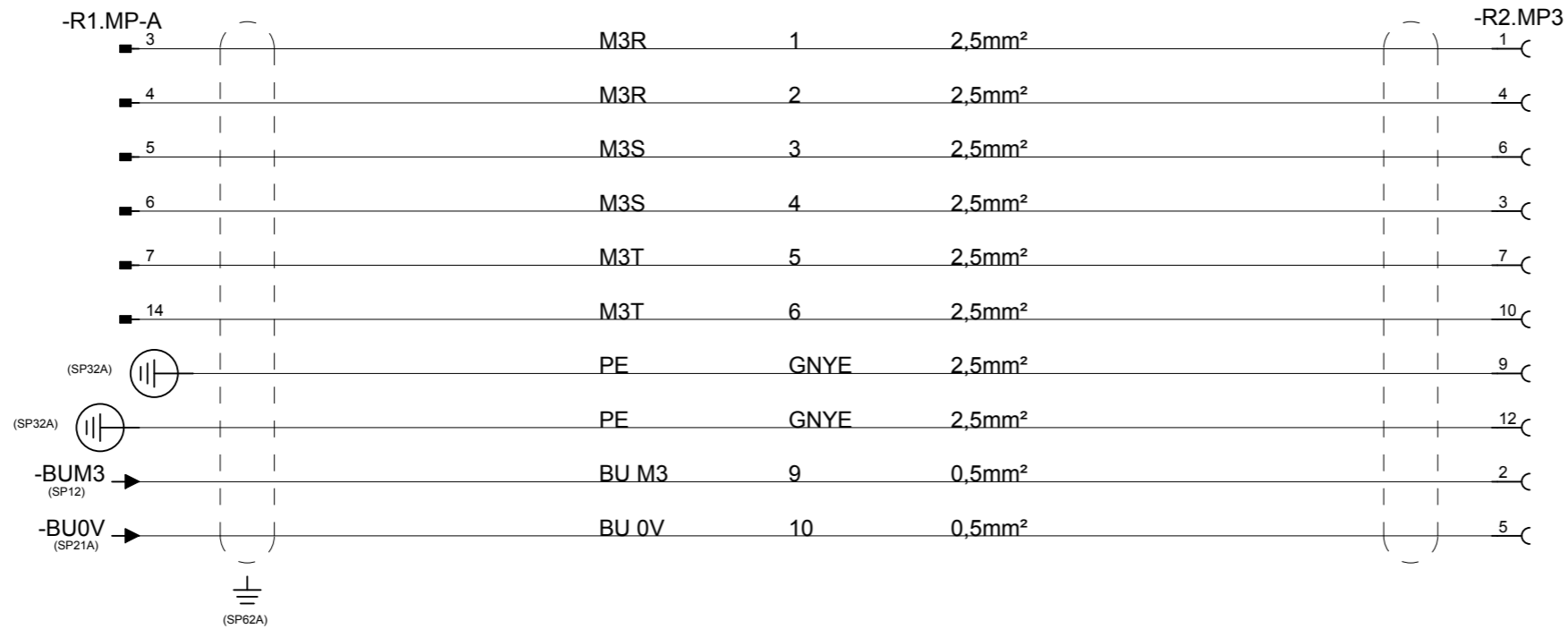

Latest revision: ECO 77348, WI 109538
Page 10: Wire no 3 added.



Lab/Office:
DMRO SE
PRIM

IRB 8700

Axis 3, incl. optional signal lamp

Status: 2016-01-14

APPROVED

Document no.

3HAC051028-002

Plant: = IRB8700

Location: + Axis 3

Sublocation: +

Rev. Ind

01

Page 50

Next +Axis 4/

Total 13

Prepared by, date: Erik Mesaros Approved by, date: Jan-Erik Nähls

We reserve all rights in this document and in the information contained therein. Reproduction, use or disclosure to third parties without express authority is strictly forbidden. © Copyright 2003 ABB

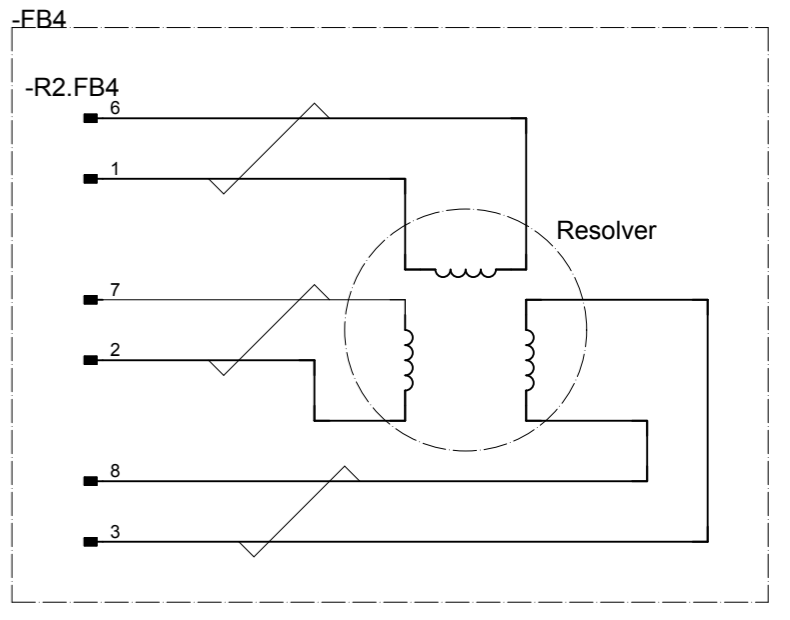
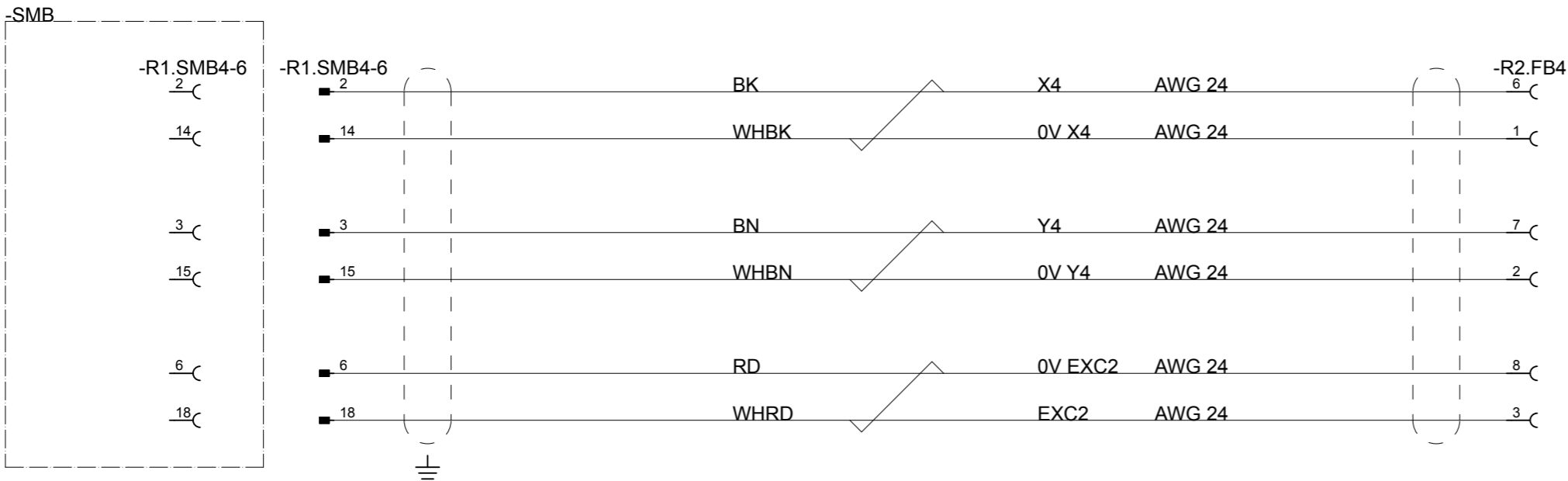
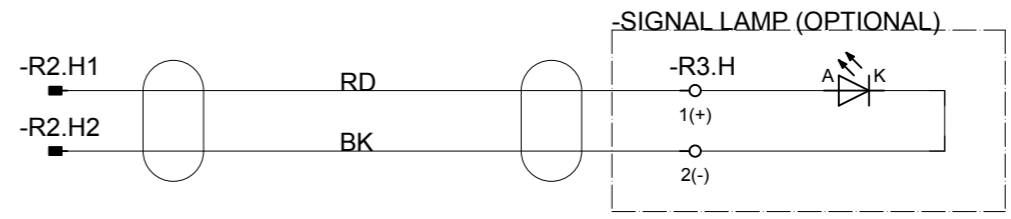
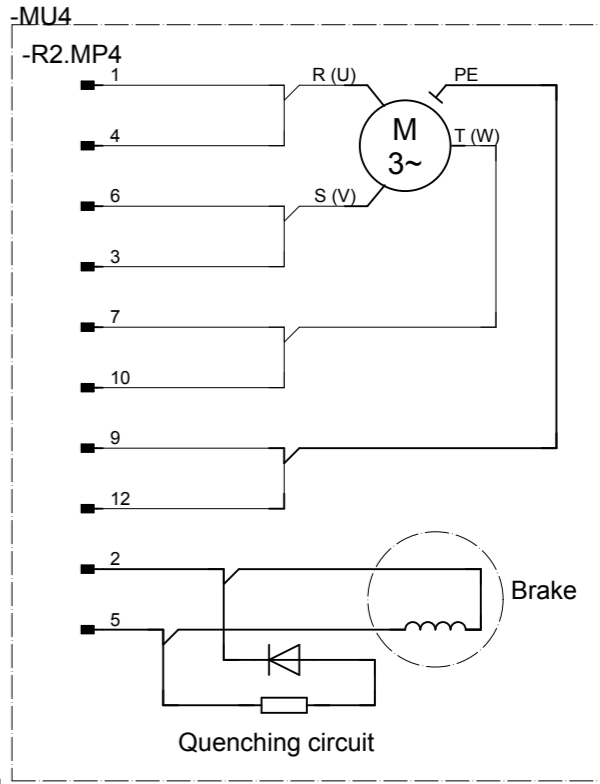
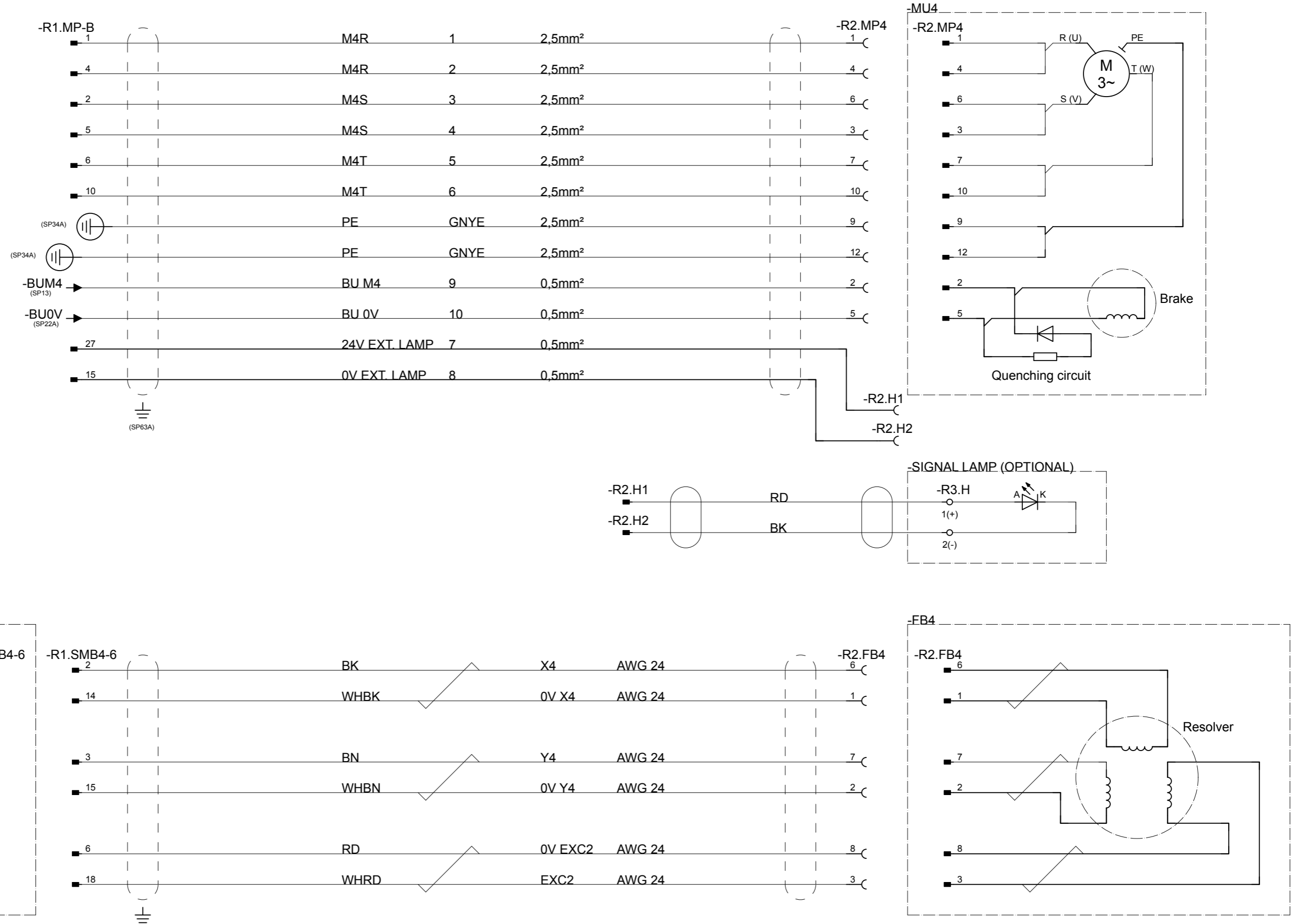

We reserve all rights in this document and in the information contained therein. Reproduction, use or disclosure to third parties without express authority is strictly forbidden. © Copyright 2003 ABB

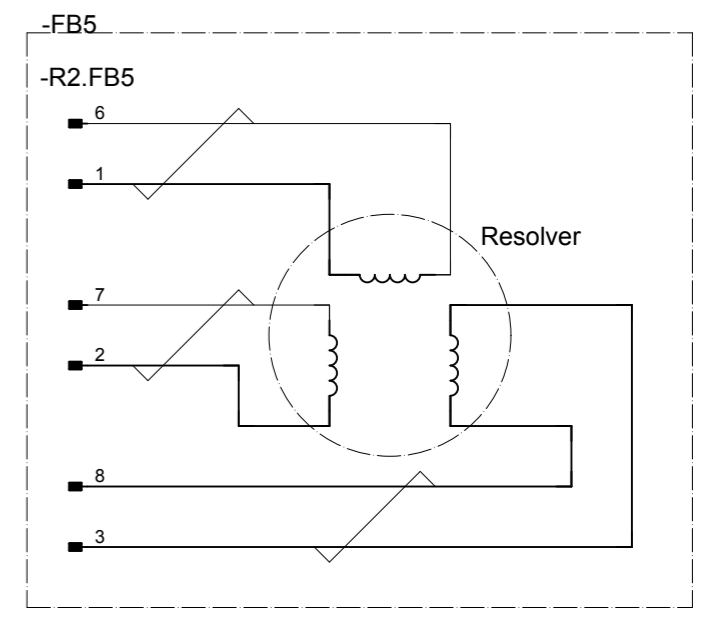
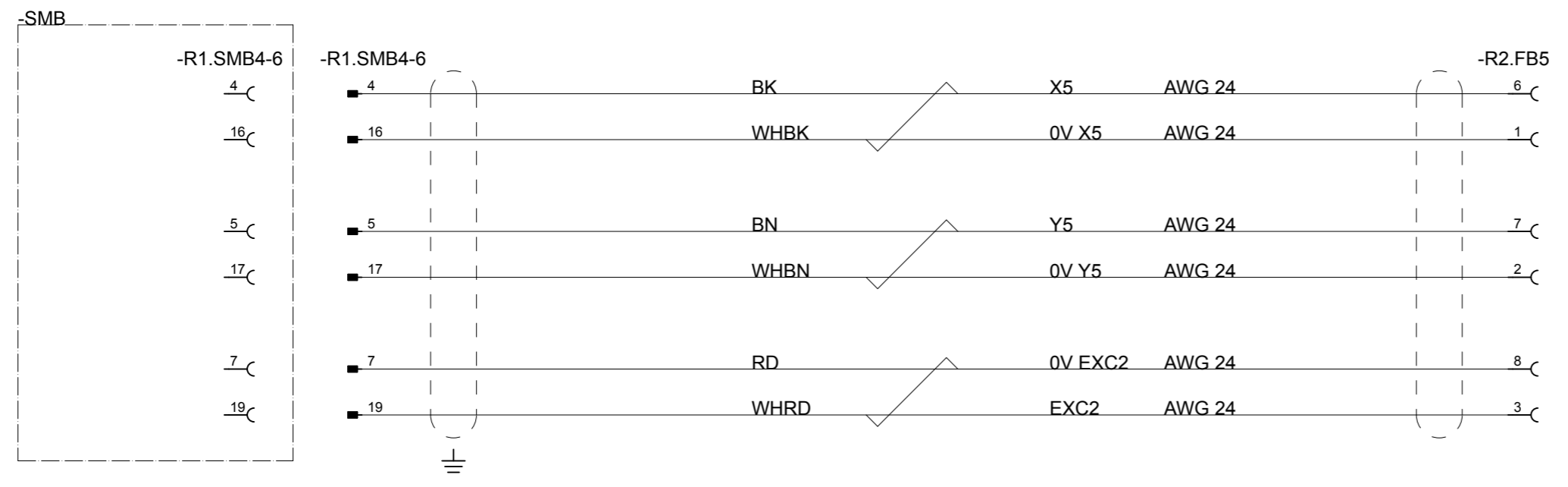
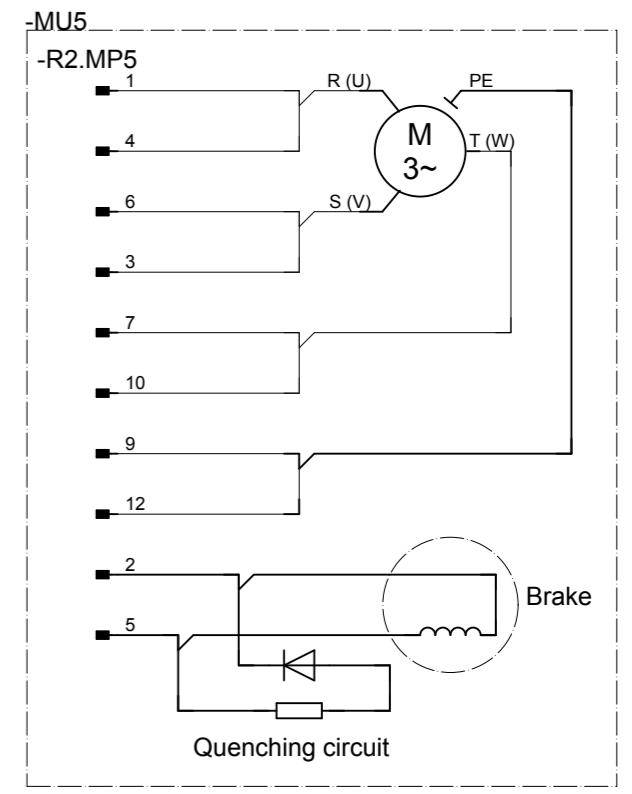
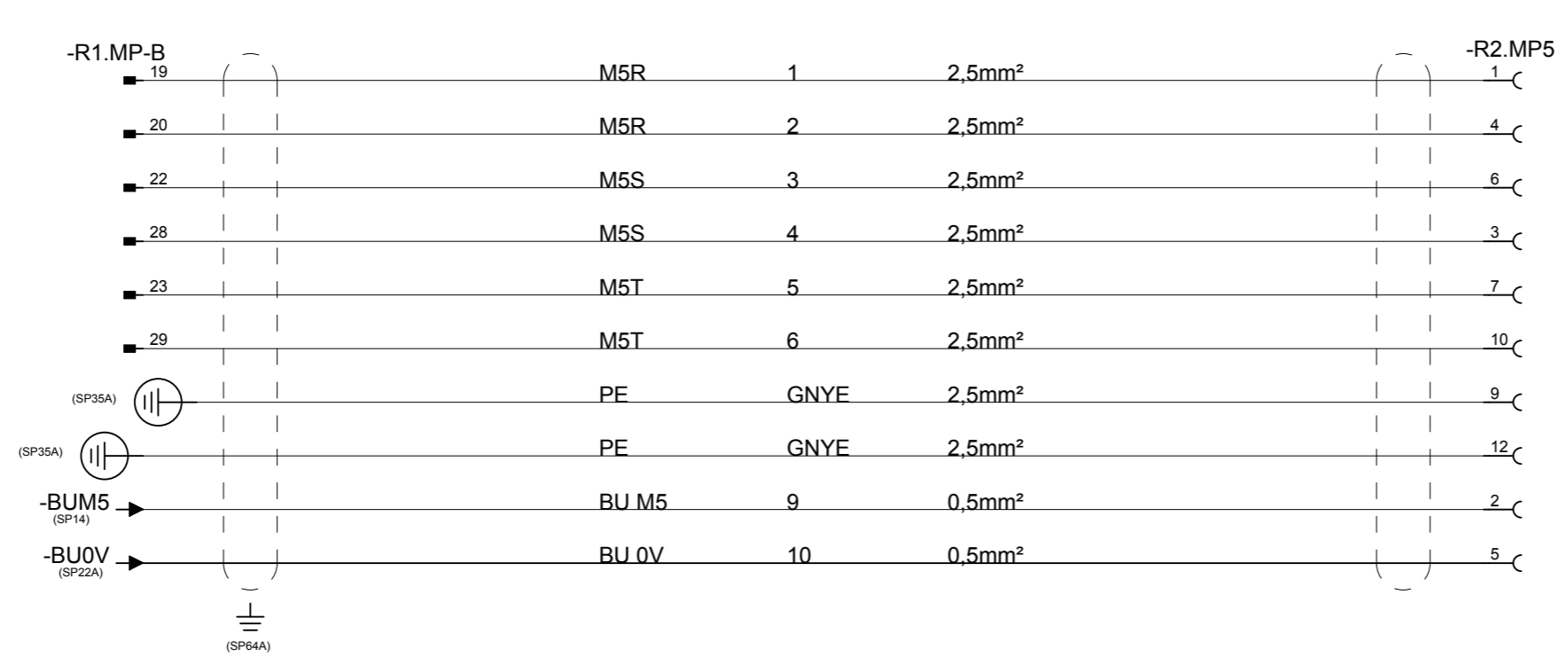

Latest revision: ECO 77348, WI 109538
Page 10: Wire no 3 added.

Prepared by, date: Erik Mesaros
Approved by, date: Jan-Erik Nähls



Lab/Office: DMRO SE PRIM
IRB 8700
Axis 5

Status: 2016-01-14
Plant: = IRB8700
Location: + Axis 5
Sublocation: +

APPROVED
Document no. 3HAC051028-002

Rev. Ind 01
Page 70
Next +Axis 6/
Total 13

We reserve all rights in this document and in the information contained therein. Reproduction, use or disclosure to third parties without express authority is strictly forbidden. © Copyright 2003 ABB

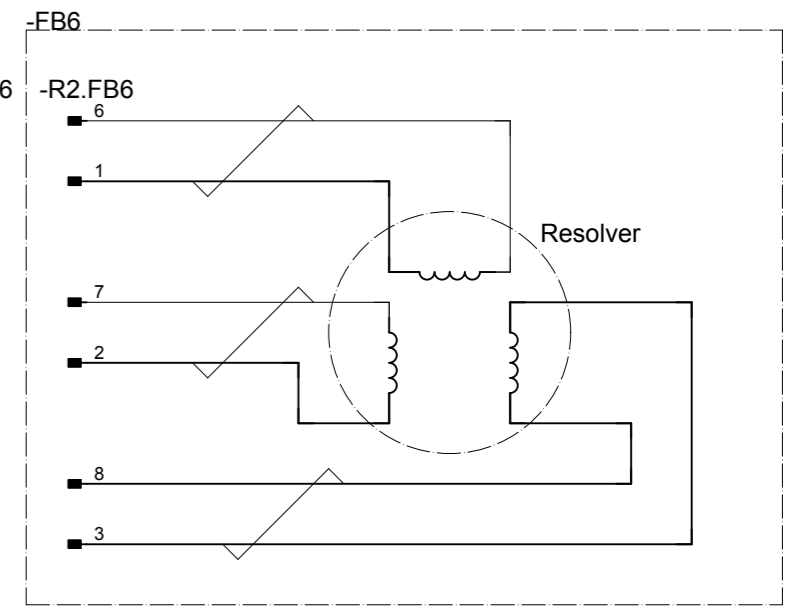
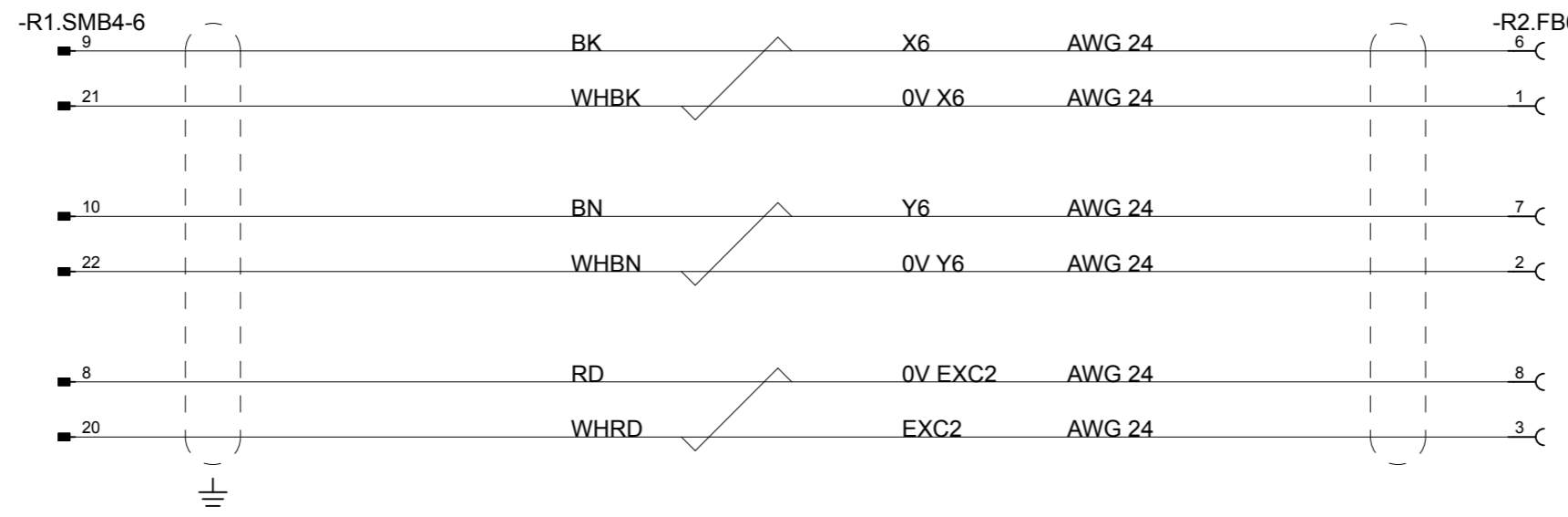
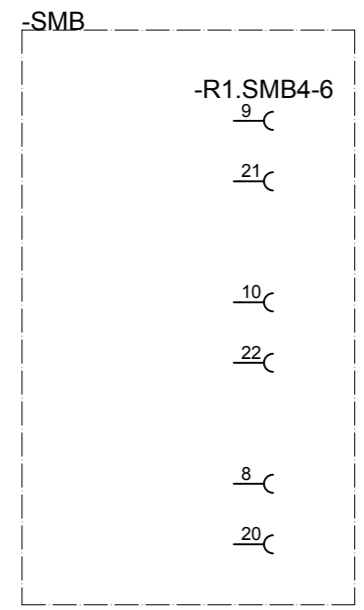
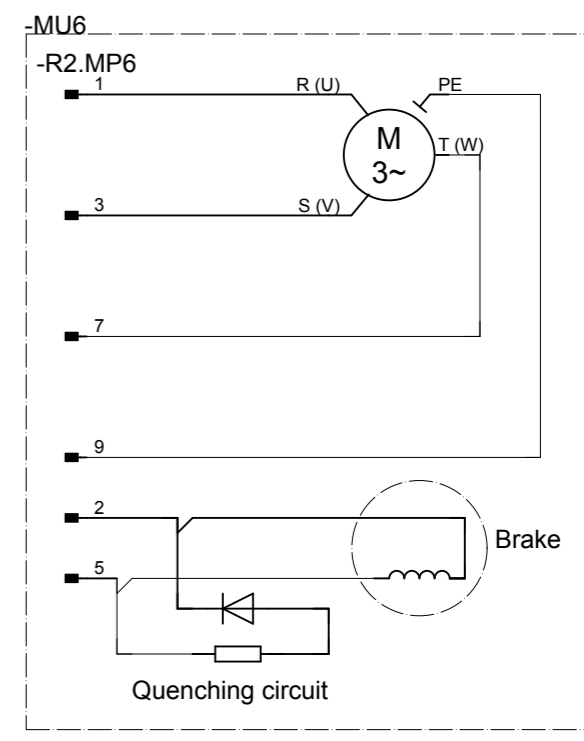
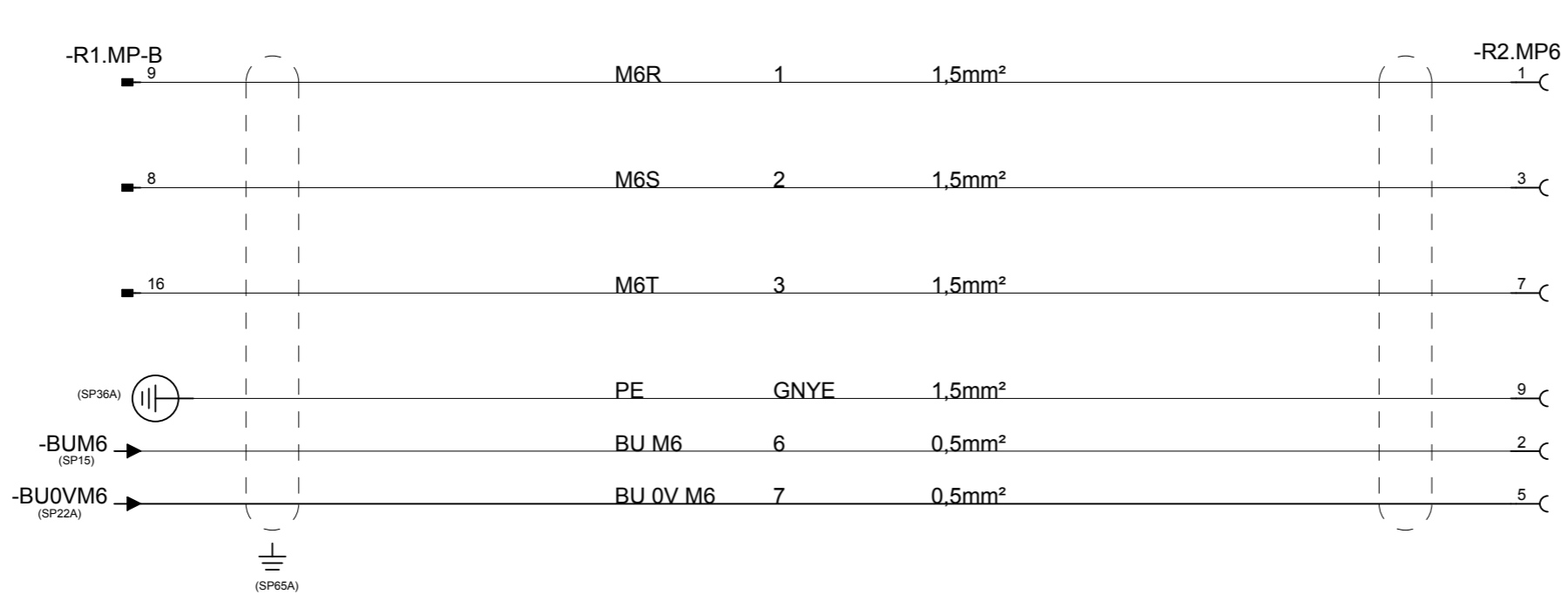

Latest revision: ECO 77348, WI 109538
Page 10: Wire no 3 added.

Prepared by, date: Erik Mesaros
Approved by, date: Jan-Erik Nähls



Lab/Office: DMRO SE PRIM
IRB 8700
Axis 6

Status: 2016-01-14
Plant: = IRB8700
Location: + Axis 6
Sublocation: +

APPROVED
Document no. 3HAC051028-002
Rev. Ind 01
Page 80
Next
Total 13